

Environmental Acquisition of Thiotrophic Endosymbionts by Deep-Sea Mussels of the Genus *Bathymodiolus*

Yong-Jin Won,^{1,2,†} Steven J. Hallam,¹ Gregory D. O'Mullan,³ Irvin L. Pan,⁴ Kurt R. Buck,¹ and Robert C. Vrijenhoek^{1*}

Monterey Bay Aquarium Research Institute, Moss Landing, California 95039-0628¹; Graduate Program in Ecology and Evolution, Rutgers University, New Brunswick, New Jersey 08901²; Department of Ecology and Evolutionary Biology, Princeton University, Princeton, New Jersey 08544³; and Molecular, Cellular, and Developmental Biology Program, Yale University, New Haven, Connecticut 06520⁴

Received 4 April 2003/Accepted 14 August 2003

Deep-sea *Bathymodiolus* mussels, depending on species and location, have the capacity to host sulfur-oxidizing (thiotrophic) and methanotrophic eubacteria in gill bacteriocytes, although little is known about the mussels' mode of symbiont acquisition. Previous studies of *Bathymodiolus* host and symbiont relationships have been based on collections of nonoverlapping species across wide-ranging geographic settings, creating an apparent model for vertical transmission. We present genetic and cytological evidence for the environmental acquisition of thiotrophic endosymbionts by vent mussels from the Mid-Atlantic Ridge. Open pit structures in cell membranes of the gill surface revealed likely sites for endocytosis of free-living bacteria. A population genetic analysis of the thiotrophic symbionts exploited a hybrid zone where two *Bathymodiolus* species intergrade. Northern *Bathymodiolus azoricus* and southern *Bathymodiolus puteoserpentis* possess species-specific DNA sequences that identify both their symbiont strains (internal transcribed spacer regions) and their mitochondria (ND4). However, the northern and southern symbiont-mitochondrial pairs were decoupled in the hybrid zone. Such decoupling of symbiont-mitochondrial pairs would not occur if the two elements were transmitted strictly vertically through the germ line. Taken together, these findings are consistent with an environmental source of thiotrophic symbionts in *Bathymodiolus* mussels, although an environmentally "leaky" system of vertical transmission could not be excluded.

Since the discovery of dense animal communities at deep-sea hydrothermal vents along the Galapagos Rift (12), vent physiologists and ecologists have focused much of their attention on the symbiotic relationships between invertebrate animals endemic to the vents and the chemoautotrophic microbes responsible for carbon fixation (6, 7, 10, 11, 21, 24). For example, mouthless, gutless, vestimentiferan tubeworms (phylum Annelida, family Siboglinidae) are emblematic of hydrothermal vents. Adult worms rely entirely on sulfur-oxidizing (thiotrophic) endosymbionts for their nutrition. The bacteria are housed in specialized cells (bacteriocytes) located in a large organ called the trophosome. Despite this complete dependence of adults on bacteria, juvenile worms must acquire the bacteria anew in each generation from the local environment (14, 37). In contrast, vesicomyid clams transmit their thiotrophic endosymbionts vertically between generations via the egg cytoplasm (5, 19, 32). The clams possess reduced or vestigial digestive tracts (3) and house their symbionts in their gill epithelia (20, 42). Other examples of symbiosis in vent animals are reviewed by Van Dover (48), but little is known about their modes of symbiont acquisition or transmission.

Bathymodiolus mussels are among the dominant constituents of deep-sea vents and sulfide-hydrocarbon cold seeps

worldwide. These mussels present a level of symbiotic complexity that is not seen in the tubeworms and clams. Some *Bathymodiolus* species house thiotrophic microbes in gill tissue bacteriocytes, others harbor methanotrophic microbes, and some harbor both types of symbionts (9, 18, 26, 43). Though mussels have functional guts and retain an ability to feed on suspended organic matter and bacteria, the digestive tract is greatly reduced in most species (22, 25, 33). Preliminary cytological investigations revealed conflicting evidence regarding symbiont acquisition. Le Pennec et al. (35) suggested that *Bathymodiolus* mussels acquire thiotrophic symbionts horizontally by endocytosis through gill epithelium. Subsequently, Cary and Giovannoni (5) suggested that the symbionts might be transmitted vertically. However, the diffusive gonads of mussels and strong background hybridization with symbiont-specific RNA probes made it impossible to specifically localize symbionts to mussel eggs or ovarian nurse cells (C. Cary, personal communication). Vertical transmission was also inferred from a phylogenetic study of bivalve host families and associated thiotrophic γ -subdivision proteobacterial symbionts that showed some congruence of branching patterns (16). Thus, subsequent authors have assumed vertical transmission of thiotrophs in *Bathymodiolus* mussels (38, 40, 47). Nevertheless, the vertical transmission hypothesis has not been tested directly in *Bathymodiolus* as it has been in vesicomyids (32).

This study employed genetic and cytological approaches to examine the transmission of thiotrophic symbionts in a natural population of *Bathymodiolus* mussels. First, we used transmission electron microscopy (TEM) to assess evidence for environmental acquisition of microbes via endocytosis across the

* Corresponding author. Mailing address: Monterey Bay Aquarium Research Institute, 7700 Sandholdt Rd., Moss Landing, CA 95039-0628. Phone: (831) 775-1799. Fax: (831) 775-1620. E-mail: vrijen@mbari.org.

† Present address: Department of Genetics, Rutgers University, Piscataway, NJ 08854.

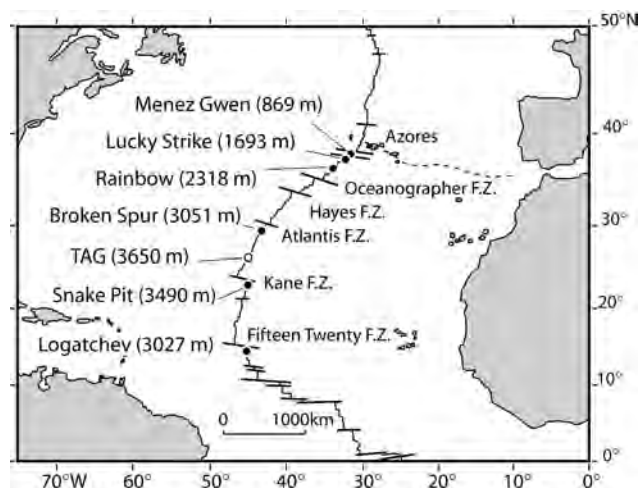

FIG. 1. Map of MAR hydrothermal vent fields and sample collection localities with average depths in meters: localities with mussels (●) and the TAG (Trans-Atlantic Geotraverse) hydrothermal field (○), which had no mussels.

gill surface. Second, we used a genetic approach to test for vertical transmission. The latter approach derives from recent findings with the clam *Calyplogena magnifica* (32). Population genetic analysis revealed that the clam's thiotrophs behave as if they were completely coupled (i.e., genetically linked) with the hosts' mitochondria, an example of strictly cytoplasmic maternal cotransmission (SCMC) (32). In this study, we exploited a recently discovered hybrid population of mussels from the Mid-Atlantic Ridge (MAR) (39) to test the SCMC hypothesis. The northern and southern mussel species (*Bathymodiolus azoricus* and *Bathymodiolus puteoserpentis*, respectively) differ diagnostically in their mitochondrial DNA (mtDNA) sequences, and they intergrade along an intermediate segment of the MAR axis (Fig. 1) (39). We show that the two species share the same 16S ribotype of thiotrophic γ -subdivision proteobacteria. However, the two host species carry different bacterial strains marked by divergent ribosomal internal transcribed spacer (ITS) sequences. Combined screen-

TABLE 2. Primers used for amplification of symbiont ITS and 16S rDNA regions

Primer name	Sequence (5'-3')	Gene (nt position ^a)
Sym-16S-20F	CTCAGATTGAACGCTGGCGG	16S rRNA (23)
Thio-sym16S-450F	ATTGGGAAGAAAAGCTAATG	16S rRNA (442)
Thio-sym16S-830F	GTTGGGAGGATTTACCTCTT	16S rRNA (832)
Sym-ITS-1322F	GTTGGAATCGCTAGTAATCG	16S rRNA (1334)
Thio-sym-ITS-450R	GACCAGGCCGACAACGCAGT	ITS-II (26)
Thio-sym-ITS-1080R	ACCATCTAAAACATGTTTCC	ITS-III (480)
Sym-ITS-23SR	ACTGCCAAGGCATCCACCGT	23S rRNA (40)
Sym-ITS-400R	CTCTAACCAACTGAGCTACA	tRNA-Ala (25)
Sym-16S-1450R	CGACTTTACCCAGTCATGA	16S rRNA (1497)

^a Position values represent the first nucleotide position of each primer corresponding to those of reference genes 16S rRNA and 23S rRNA of *E. coli* strain K-12 (GenBank accession no. NC_000913) and those of ITS-II, ITS-III, and tRNA-Ala of thiotrophic bacteria of *B. puteoserpentis* (GenBank accession no. U29163).

ing of bacterial ITS and host mtDNA sequences allowed a test of the SCMC hypothesis in mussels from the hybrid zone population.

MATERIALS AND METHODS

Specimens. We used the deep-sea submersible *Alvin* to collect *Bathymodiolus* mussels from six hydrothermal vent fields along the MAR (Fig. 1) (Table 1). Aboard the research vessel, we immediately froze whole small mussels (length, up to 25 mm) at -70°C. Larger specimens were dissected, and samples of adductor muscle, gill, and mantle tissues were frozen at -70°C. Gill tissues from representative individuals were fixed in 2% glutaraldehyde (electron microscopy grade; Sigma), diluted in 0.2 μ M filtered seawater, and stored at 4°C. These gill samples were postfixed for TEM, dehydrated, infiltrated, and polymerized using microwave techniques (29). Thin sections were cut, stained with lead citrate, and placed on Formar-coated grids for viewing with either a JEOL 100B or a 1200EX TEM.

Molecular methods. We used a DNA isolation kit (Qiagen, Inc., Valencia, Calif.) to extract host and bacterial DNAs from tissue samples. For mitochondrial studies, we excised a small portion (~50 mg) of adductor muscle. Methods for amplification, sequencing, and restriction fragment length polymorphism (RFLP) analysis of the mitochondrial ND4 sequences were previously described (36). Bacterial DNA was extracted from a gill tissue sample (~50 mg) from each mussel. To specifically amplify DNA sequences from the thiotrophs, we designed a series of primer sets targeting the ITS region and flanking 16S rDNA of the ribosomal operon (Table 2) (17, 18, 28, 40). To aid the design process, we used Clustal X version 1.81 (46) to align published sequences from the following bacteria. To analyze *Bathymodiolus* gill symbiont 16S rRNA, we used *B. puteoserpentis* (GenBank accession number U29164; methanotrophic endosymbiont),

TABLE 1. Sample locations, *Alvin* dive numbers, and collection dates for *Bathymodiolus* samples

Region	Location	Dive no.	Date mo/day/yr	Latitude	Longitude	Depth (m)
North	MG	3117	7/7/97	37°50.36'N	31°31.28'W	869
North	LS	3680	7/25/01	37°17.26'N	32°16.51'W	1,692
		3681	7/26/01	37°17.26'N	32°16.48'W	1,647
		3682	7/27/01	37°17.29'N	32°16.46'W	1,700
		3120	7/10/97	37°17.63'N	32°16.53'W	1,733
		3677	7/22/01	36°13.44'N	33°53.58'W	2,318
North	RB	3678	7/23/01	36°13.50'N	33°53.90'W	2,305
		3121	7/11/97	36°14.24'N	33°54.09'W	2,330
		3676	7/19/01	29°10.03'N	43°10.45'W	3,045
Hybrid	BS	3125	7/17/97	29°10.00'N	43°10.4'W	3,056
3129		7/22/97	23°22.20'N	44°57.04'W	3,510	
South	SP	3672	7/14/01	23°22.10'N	44°56.91'W	3,492
		3673	7/15/01	23°22.13'N	44°57.00'W	3,490
		3674	7/16/01	23°22.13'N	44°57.00'W	3,491
		3666	7/6/01	14°45.31'N	44°58.31'W	3,023
South	LO	3667	7/1/01	14°45.27'N	44°58.70'W	3,027
		3668	7/8/01	14°45.42'N	44°58.79'W	3,028

Bathymodiolus thermophilus (GenBank accession number M99445; thiotrophic endosymbiont), *B. puteoserpentis* (GenBank accession number U29163; sulfur bacteria), and *Bathymodiolus septemdirum* (GenBank accession number AB036709; sulfur bacteria); to analyze 23S rRNA sequences, we used *Aeromonas hydrophila* (GenBank accession number X87281), *Bacillus halodurans* (GenBank accession number AB031211), *Escherichia coli* (GenBank accession number NC_000913), and endosymbiont of *Heteropsylla texana* (GenBank accession number AF263562). The contiguous amplified sequences spanned most of the 16S gene and the entire linked ITS region.

PCR mixes included 30 to 100 ng of template DNA, 5 μ l of 10 \times buffer (Promega, Inc., Madison, Wis.), 5 μ l of MgCl₂ (2.5 μ M), 2 μ l of each primer (final concentration, 10 μ M), 2.5 U of *Taq* polymerase (Promega, Inc.), 5 μ l of a 2 mM stock solution of deoxynucleoside triphosphates, and sterile H₂O to a final volume of 50 μ l. PCRs were carried out under the following conditions: 37 cycles of 94°C for 40 s, 55°C for 1 min, and 72°C for 1 min and a final extension step at 72°C for 7 min.

Purified templates were sequenced using Big Dye Terminator cycle sequencing reaction kits (PE Biosystems, Foster City, Calif.) and ABI Prism 3100 DNA sequencers (Applied Biosystems, Inc., Foster City, Calif.). Bidirectional sequences were obtained using the same forward and reverse PCR primers. PCR products from individuals found to contain multiple symbiont sequences were reanalyzed by cloning and sequencing. These heterogeneous PCR samples were purified by gel excision, cleaned with the Qiaquick gel purification kit (Qiagen, Inc.), and cloned using the TOPO TA cloning kit (Invitrogen, Carlsbad, Calif.). Colonies grown on agar plates were cultured in liquid Luria-Bertani medium overnight, and plasmid DNAs were extracted with the Qiaquick plasmid mini-prep kit (Qiagen, Inc.).

Southern blot analysis of bacterial ITS was conducted with genomic DNA extracted from gill tissues. We used *Tsp*RI to digest 14 μ g of genomic DNA from a sample of 10 mussels (a representative individual from both of the parental species and 8 individuals from the hybrid population, including 4 mussels harboring single-symbiont types and 4 mussels harboring mixed-symbiont types). Restriction fragments were separated in a 1% agarose gel and transferred to a nylon membrane (Hybond N+ membrane; Amersham Pharmacia Biotech, Inc., Piscataway, N.J.). A single *B. azoricus* mussel (Lucky Strike [LS] locality) was used to generate a thiotroph-specific ITS probe (350 bp) that was a product of the SYM-ITS607 (forward, 5'-TGG CTC CAC CAC ATT GTT T-3') and SYM-ITSR (reverse, 5'-TCA TAC AGT TAG TAT TTC ACC-3') primers (Table 2). Fluorescent labeling of the probe, hybridization, and signal amplification of hybridized probe were performed according to the manufacturer's protocols (Amersham Bioscience, Inc., Piscataway, N.J.). We quantified the relative amount of labeled probe bound to target DNA with the FluorImager and ImageQuant software (Amersham Bioscience).

Assignment test and phylogenetic methods. We used the computer program WHICHRUN version 4.1 (1) to estimate the likelihoods of assignment of individual mussels to either of the parental species. The allozyme and mtDNA data used in this analysis were obtained from a study of cytonuclear disequilibrium in the hybrid zone study (51). The probability of obtaining each multilocus genotype (based on five allozyme loci and one mitochondrial haplotype) is estimated from the combined (multiplicative) probability of obtaining each single-locus genotype in a reference population. These are based, in turn, on the randomizing expectations of obtaining each single-locus genotype in each parental population. Samples from the parental populations comprised 79 northern (*B. azoricus*) and 32 southern (*B. puteoserpentis*) individuals. We used the logarithm of the odds (LOD) ratio as a criterion for assignment and designated ranges of ± 2 as guides for assignment of individuals to parental populations. A LOD score greater than +2 or less than -2 implies a less than 1% chance of error in assigning a genotype to one of the two parental groups. Estimates of pairwise sequence divergence and phylogenetic analyses among host and symbiont sequences were obtained with MEGA version 2.1 (34).

Nucleotide sequence accession numbers. The new symbiont ITS sequences have been deposited in GenBank under accession numbers AY235678 (*sym-az*), AY235679 (*sym-pu1*), and AY235680 (*sym-pu2*).

RESULTS

Microscopy. To assess whether *Bathymodiolus* spp. might obtain symbionts from the environment, we performed TEM analysis on the gill tissue from several hybrid zone mussels. The thiotrophs are rod- or coccus-shaped in cross section, ranging in size from 0.5 to 2.0 μ m (Fig. 2A and B) (9, 22, 23,

26). The methanotrophs are also coccoid and range in size from 1.4 to 2.0 μ m, but they possess the characteristic stacked membranes of Type 1 methanotrophs (8, 9) (Fig. 2A and B). All symbionts were encapsulated in vacuoles within the bacteriocytes, typically containing many thiotrophs and one methanotroph per vacuole (Fig. 2A and B). The apical surface of the bacteriocytes possessed numerous microvilli (Fig. 2A through C). Invaginations and discontinuities in the membrane at this surface are consistent with the process of endocytosis (Fig. 2B and C). Evidence for digestion of bacteria is found in the basal region of some of the sectioned bacteriocytes. Numerous lysosomal vesicles possess large amounts of membranous material, which is assumed to be bacterial remnants (Fig. 2D).

Host mitochondrial variation. A 721-bp region of mtDNA, encompassing two transfer RNAs (166 bp) and the first third of the ND4 coding sequence (555 bp), was used in determining genetic variation between mussel hosts. All mussels from the northern region (Menez Gwen [MG], LS, and Rainbow [RB]) had *B. azoricus* (hereinafter called *mt-az*) mitochondrial haplotypes, and all mussels from the southern region (Snake Pit [SP] and Logatchev [LO]) had *B. puteoserpentis* (hereinafter called *mt-pu*) haplotypes. Samples from the mussel hybrid zone (Broken Spur [BS]) had an even mixture of the two major haplotypes (*mt-az*, 23; *mt-pu*, 24) (Table 3). Average sequence divergence between ND4 sequences from the two species was ~11%. Thirteen amino acid substitutions distinguish the ND4 coding regions of the *mt-az* and *mt-pu* haplotypes. Representative ND4 sequences of the two types were previously deposited under GenBank accession numbers AF128533 (*B. puteoserpentis*, the *mt-pu* type) and AF128534 (*B. azoricus*, the *mt-az* type) (36).

Symbiont ITS variation. Approximately 1,200 bp of the symbiont 16S rDNA ITS sequence was amplified with Sym-ITS-1322F forward and Sym-ITS-23SR reverse primers. An 1,113-bp portion of this product was used to examine genetic diversity among the endosymbiotic thiotrophs. Comparison of DNA sequences of the PCR-amplified ITS was confined to a region that included 152 bp from the terminus of 16S rDNA, all of ITS, 85 bp of tRNA-Ala, 77 bp of tRNA-Ile, and 3 bp of 23S rDNA. Based on variation in the ITS region, we identified three distinct bacterial strains that could be grouped into two major lineages, *sym-az* and *sym-pu* (Fig. 3). The *sym-az* and *sym-pu* lineages exhibited fixed differences at 11 positions that included a 2-bp indel at sites 492 to 493, a 1-bp indel at site 654, and eight nucleotide substitutions. *Sym-pu* comprised two subtypes, *sym-pu1* and *sym-pu2*, which differed at five positions. *Sym-az* exhibited a single polymorphism, substituting A for C at nucleotide position 352.

Outside the hybrid zone, the *sym-az* and *sym-pu* types corresponded exactly with the northern and southern mitochondrial ND4 haplotypes, *mt-az* and *mt-pu* (Table 3). Only the *sym-az-mt-az* pair occurred at the northern vent fields (MG, LS, and RB), and only the *sym-pu-mt-pu* pair occurred at the southern fields (SP and LO). Analysis of an extended region of bacterial 16S rDNA sequences (1,425 bp) in mussels taken from northern and southern parental regions revealed a single common ribotype sequence (GenBank accession number AY235677) that was coupled with both the *sym-az* and the *sym-pu* ITS sequences. However, at one northern locality

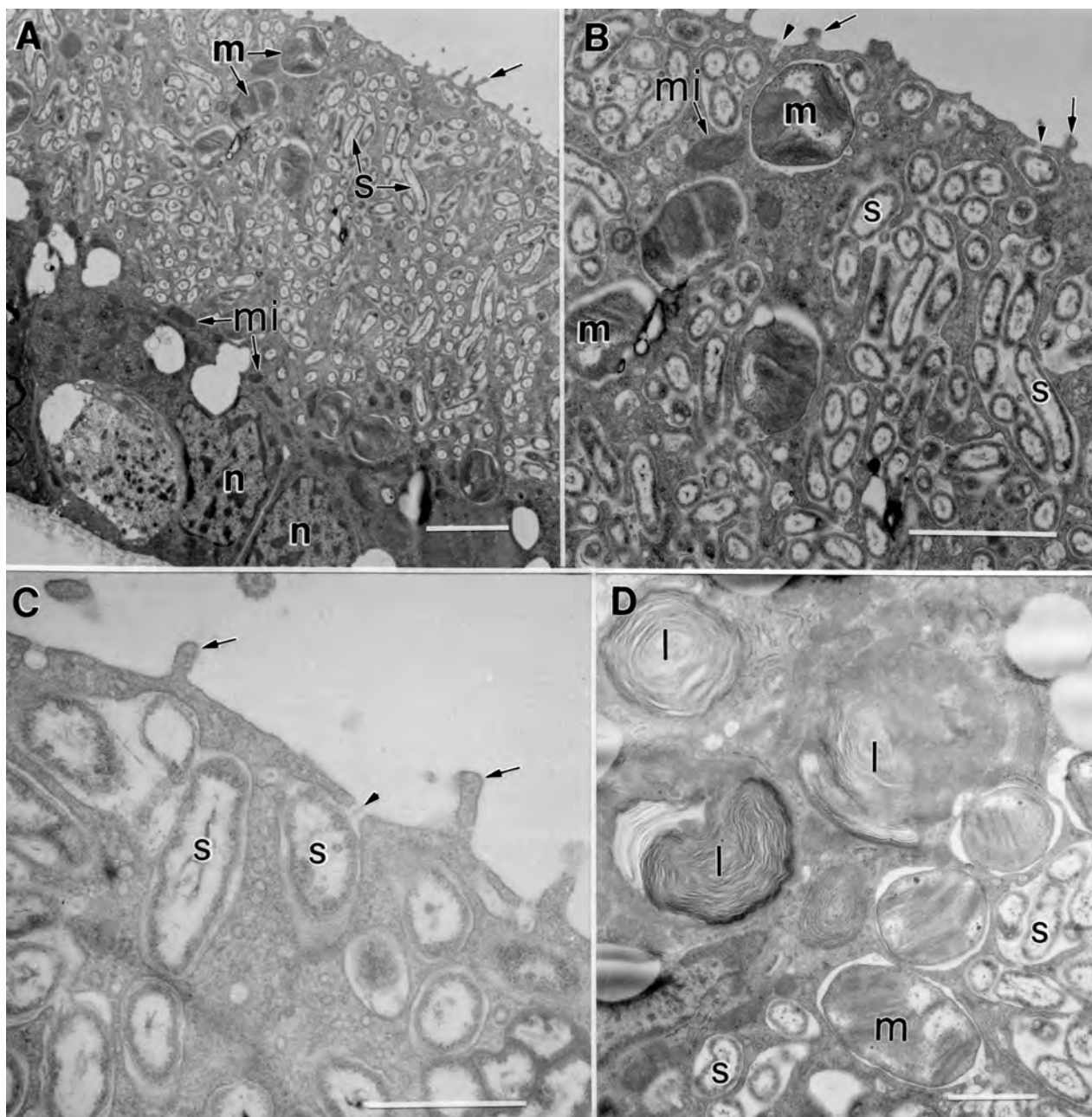

FIG. 2. Transmission electron photomicrographs of gill filament from *Bathymodiolus*. (A) Gill filament cells showing microvilli (arrow at surface), nuclei (n), thiotrophic symbionts (s), methanotrophic symbionts (m), and mitochondria (mi). Scale bar, 2 μm . (B) Vacuoles near microvilli contain microbes, and some connect with the surface through invaginations (arrowheads) that are indicative of endocytosis. Scale bar, 2 μm . (C) High magnification of vacuoles near apical surface showing thiotrophic endosymbionts and invaginations consistent with endocytosis (arrowhead). Scale bar, 1 μm . (D) Lysosomal vesicles (l) in the vicinity of thiotrophic and methanotrophic endosymbionts. Scale bar, 1 μm .

(RB), we found a second ribotype (GenBank accession number AY235676) that differed at three nucleotide positions and was also coupled with *sym-az* ITS.

The hybrid zone sample of 47 mussels contained both the *sym-az* and *sym-pu* symbiont sequences, though *sym-pu* was far more abundant (Table 3). Forty-two mussels, harboring *sym-pu*, were evenly divided between individuals with the *mt-az* ($n = 18$) and *mt-pu* ($n = 24$) mitochondrial haplotypes. No hybrid zone mussels had just *sym-az*, but five mussels contained both

the *sym-az* and the *sym-pu* sequences. These mixed ITS types were first detected in PCR-generated DNA sequences, but cloning and sequencing confirmed the occurrence of both sequences in individual mussels. Mixed ITS sequences (*sym-pu1-sym-pu2*) were also observed in a sample of 10 individuals from the LO vent field, which is outside the hybrid zone (Table 3). Cloning and sequencing from one of these LO individuals also confirmed the presence of both *sym-pu1* and *sym-pu2* variants.

The mixed-symbiont sequences from individual mussels

TABLE 3. Associations between mussel hosts and thiotrophic symbionts showing mitochondrial ND4 haplotypes and ITS sequence variants

Location	No. with host ND4 (mt) haplotype:		No. with symbiont ITS (sym) haplotype:				n
	az	pu	az	pu1	az/pu1 ^a pu1/pu2 ^b		
MG	3		3				3
LS	12		12				12
RB	9		9				9
BS	23	24		42	5		47
SP		10		10			10
LO		10				10	10

^a Mixture of symbiont haplotypes *sym-az* and *sym-pu1*.
^b Mixture of symbiont haplotypes *sym-pu1* and *sym-pu2*.

could result from the co-occurrence of distinct symbiont strains, or they might be due to variation among two or more (homologous) ribosomal operons within individual microbial cells (13). To assess these alternatives, we performed Southern blot analysis (Fig. 4). The *sym-az* and *sym-pu* ITS sequences encompass a polymorphism at position 957 that is recognized by *TspRI* restriction endonuclease. Three nonpolymorphic *TspRI* sites also occur in the flanking 16S rDNA region. The 350-bp ITS probe discriminated between *sym-az*- and *sym-pu*-specific RFLP fragments that differed by ~150 bp. All northern and southern parental individuals showed only a single band (A or P, respectively), as predicted from the *sym-az* and



FIG. 4. RFLP analysis of whole DNA extracted from mussel gills and probed with a 350-bp fragment of ITS complementary to that of the thiotrophic endosymbionts. S, southern *B. puteoserpentis*; H, hybrid zone samples; N, northern *B. azoricus*; p, mitochondrial type *mt-pu*; a, mitochondrial type *mt-az*; P, southern ITS type *sym-pu1*; M, mixed ITS types; A, northern ITS type *sym-az*. Lane 11 contains sample 10 diluted 1/30 parts with water.

sym-pu1 sequences (Fig. 4, lane 1 versus lane 10). Four mixed individuals from the hybrid zone exhibited both the P and A bands in various ratios (Fig. 4, lanes 2 through 5). The fifth mixed individual was small and provided insufficient DNA for the Southern blot analysis. Variation in the ratio of P and A bands ranged from 0.108 to 0.695. The remaining hybrid zone mussels exhibited only the P band. Various band ratios in the mixed mussels might result from multiple operons if we hypothesize the existence of at least eight ribosomal copies composed of various proportions (e.g., 8:0, 7:1, 6:2, . . . , 0:8) of two

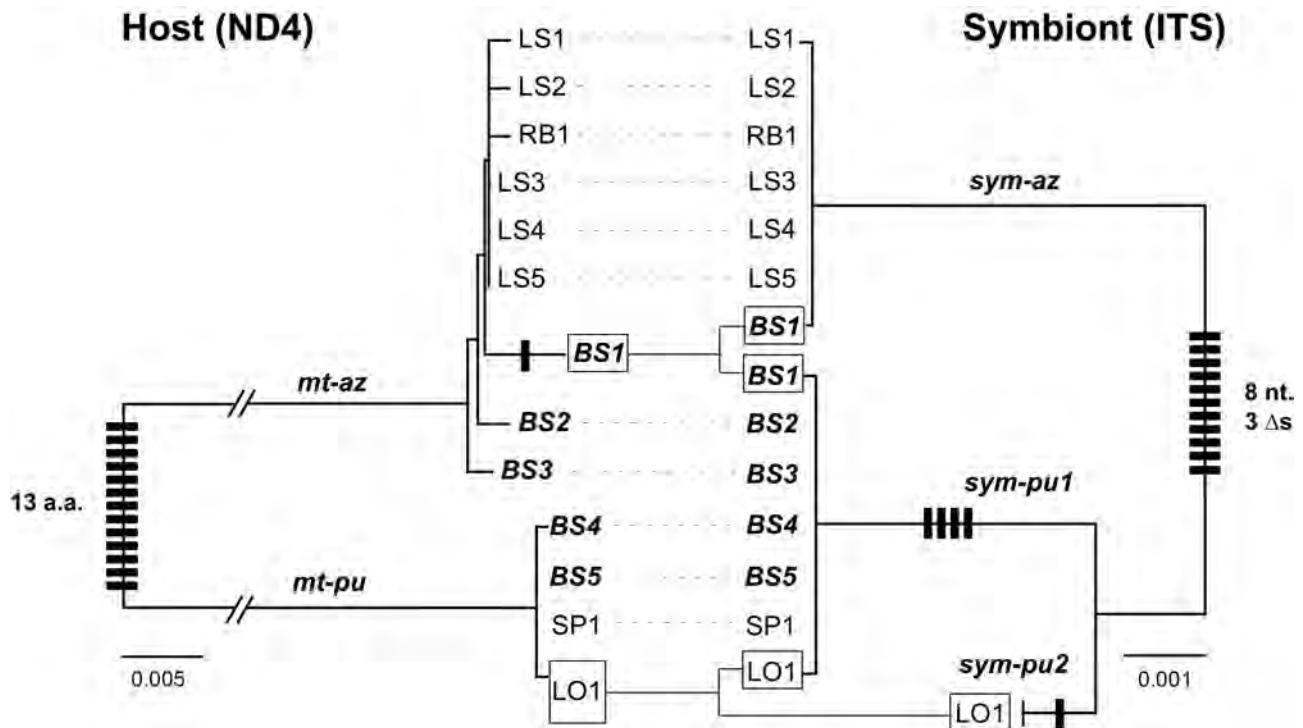

FIG. 3. A comparison of host mitochondrial ND4 (left) and symbiont ITS (right) gene trees. Co-occurring host and symbiont sequences are linked by dotted lines. Mitochondrial haplotypes that occurred with mixed-symbiont strains are marked with boxes. Branch lengths are proportional to the inferred amount of change along each branch (scales shown). Filled rectangles represent nonsynonymous nucleotide substitutions in the ND4 tree and nucleotide substitutions (nt.) and indels (Δs) in the ITS tree. Haplotype designations correspond with abbreviations for sample locations (Table 1).

homologous sequences. We consider this scenario highly unlikely, however. A simpler hypothesis is that the mixtures resulted from co-occurrence of divergent ITS strains that varied in proportion among individual mussels.

Correspondence of mtDNA and symbiont ITS in hybrid zone. To assess possible origins (parental immigrants versus native hybrids) of hybrid zone individuals, we conducted a genotypic assignment test based on the previously published allozyme and mitochondrial ND4 data (51). Here, we superimposed the symbiont types on these genotypic assignments of individual hybrid zone mussels. A plot of log-likelihood scores of multilocus genotypes from the two parental species was capable of assigning most individuals to the correct parental population (Fig. 5A). A few northern mussels (6 out of 79 individuals) could not confidently be assigned to *B. azoricus*. All southern individuals were confidently assigned to *B. puteoserpentis* (Fig. 5A). As expected, genotypic assignments of hybrid zone mussels spanned the entire field of likelihoods (Fig. 5B). What is relevant to the present study is the assignment of hybrid zone individuals with mixed (*sym-az-sym-pu1*) ITS types (Fig. 5B). Four of the five mixed-symbiont mussels were assigned to *B. azoricus*. Although assignment of the fifth mixed-symbiont mussel was equivocal, it also fell within the region expected for parental *B. azoricus*. The multilocus genotypes of these mixed-symbiont mussels were consistent with expectations for recent immigrants to the BS locality.

DISCUSSION

The present cytological and genetic analyses are completely consistent with horizontal transfer as the primary mode of acquisition of thiotrophic γ -subdivision proteobacteria by *Bathymodiolus* spp. mussels. Transmission electron photomicrographs of gill tissue bacteriocytes show a potential path for environmental endocytosis of bacteria by these mussels, as previously suggested (31, 35). Apical portions of bacteriocytes contained intracellular bacterium-containing vacuoles, often connected to cell membranes by narrow ducts (Fig. 2) that appear to contact the external environment. Similar open vacuoles are found in bacteriocytes of a vent gastropod, *Alviniconcha hessleri*, which is believed to acquire its thiotrophic endosymbionts environmentally (19). Open vacuoles are also found in another symbiont-bearing vent gastropod, *Ifremeria nautilei* (50), and in a thyasirid cold-seep clam, *Maorithyas hadalis* (27). Endocytosis of free-living bacteria appears to be a common path used by vent and seep mollusks to acquire chemoautotrophic symbionts. In contrast, vertical transmission of symbionts via the egg cytoplasm, as seen in vesicomid and solemyid bivalves (4, 5, 19, 30, 32), may be less common among mollusks.

Discovery of a hybrid zone involving *B. azoricus* and *B. puteoserpentis* mussels from the MAR (39) provided a window through which we could view the transmission mode of thiotrophic endosymbionts. According to the SCMC hypothesis, symbionts that are transmitted strictly vertically through the egg cytoplasm should behave as if they are coupled (i.e., genetically linked) with the host's mitochondria (32). In a hybrid zone between species that possess genetically divergent mitochondria and symbionts, these cytoplasmic elements should remain coupled as long as there is no possibility of leakage or

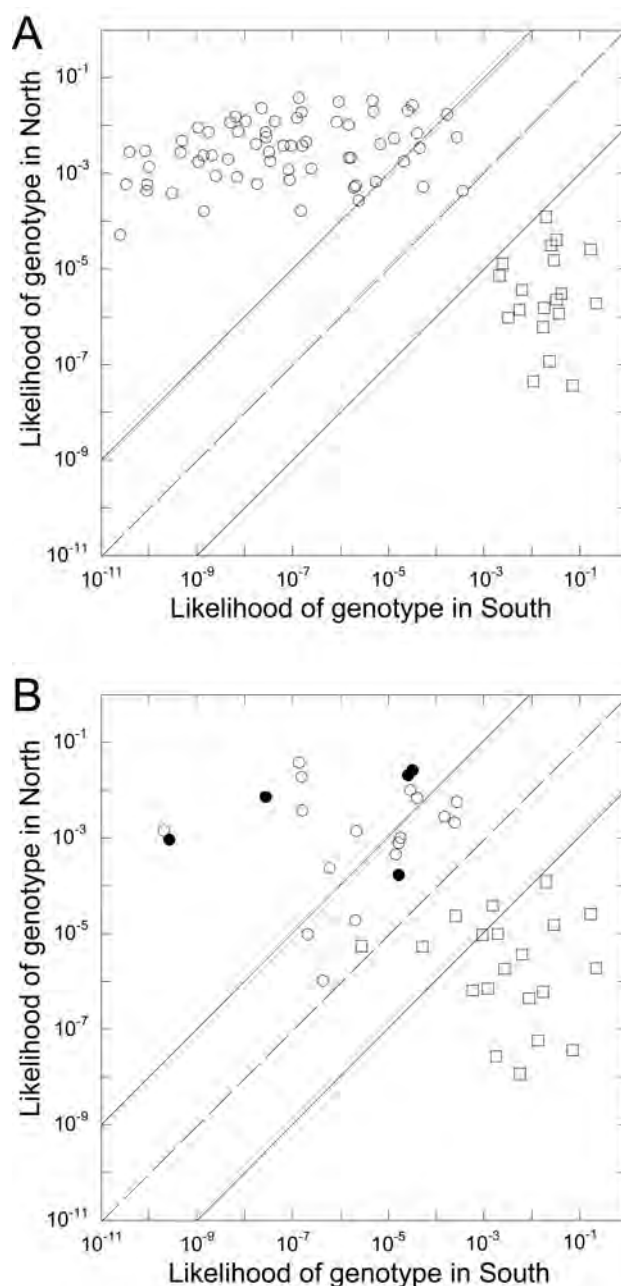

FIG. 5. Assignment plots of individual multilocus genotypes from *Bathymodiolus* mussels. (A) Samples collected from the parental regions including *B. azoricus* (○) and *B. puteoserpentis* (□). (B) Samples collected from the hybrid zone. Filled circles mark individuals harboring both the northern and southern ITS types of the thiotrophic bacteria. The dotted diagonal line represents equal probability of assignment to the northern and southern species. The two parallel solid lines represent values of ± 2 of the LOD ratio.

horizontal transfer among host individuals. We examined species-specific sequence differences in the host mitochondrial ND4 gene (*mt-az* and *mt-pu*) and ribosomal ITS regions (*sym-az* and *sym-pu*) to test the SCMC hypothesis. Clearly, host mitochondrial and symbiont types of hybrid zone mussels occurred in new combinations not observed in either of the

parental species, a result that is inconsistent with expectations of the SCMC hypothesis.

We also interpreted apparent mixtures of thiotrophic symbiont sequences from individual mussels as being inconsistent with expectations from the SCMC hypothesis. Strictly cytoplasmic transmission of symbionts should quickly lead to homoplasmy of symbionts, as it does for mitochondria (2). Each egg generation creates a population bottleneck that will be accompanied by random loss of symbiont variation, resulting in fixation of a single symbiont type. Several mussels from the hybrid zone and all mussels from a nonhybrid locality (i.e., LO) exhibited multiple symbiont ITS sequences. Although we cannot completely exclude the possibility that the mixed ITS sequences derived from multiple divergent (homologous) ribosomal operons in each bacterial cell, we consider this hypothesis highly unlikely given the variable proportions of these sequences seen among individual host mussels. Coinfection of these mussels by multiple thiotrophic strains is a simpler explanation. These mussels were simultaneously infected with methanotrophic endosymbionts, but the ITS region of the methanotrophs (S. Hallam, unpublished data) differed greatly from that of the thiotrophs. Our design of thiotroph-specific primers allowed us to clearly discriminate among the ITS regions of the two symbiont species.

Although we can reject SCMC for these mussels, the present results do not necessarily prove the alternative, that the thiotrophic symbionts are acquired strictly *de novo* from the environment during each host generation. Leaky modes of vertical transmission can also lead to multiple infections and instances of host-symbiont recombination similar to those seen in the present study. For example, predominantly vertical transmission of *Wolbachia* endosymbionts of some insects is augmented by occasional reinfection, which leads to double infections and potential sorting and replacement of symbiont strains (41, 49). Also, foreign bacteria might invade the egg cytoplasm via sperm. Shallow-water mytilids transmit mitochondria through eggs and sperm, known as doubly uniparental inheritance (reviewed in references 45 and 52). Thus, sperm leakage and reinfection could produce heteroplasmic mixtures of mitochondria and symbionts that facilitate their decoupling. Nevertheless, cytological investigations of *Bathymodiolus* sperm and eggs have revealed no evidence for bacterial inclusions (31).

Preliminary evidence suggests that *Bathymodiolus* juveniles are infected with symbionts at an early life stage. Electron microscopy revealed the presence of thiotrophic bacteria in newly settled pediveliger larvae of *B. azoricus*, and symbiont-specific ITS sequences were amplified directly from these larvae (J. Salerno, personal communication). These larvae might have inherited bacteria from their mothers or acquired them immediately following settlement. If acquired from their mothers, or if larvae were infected prior to dispersal from the natal site, symbionts will remain coupled with the mitochondrial types also found at the natal site. Nevertheless, horizontal transfer following settlement at a new locality could replace natal symbionts. This scenario might explain the mixture of symbiont types seen in the five hybrid zone mussels from BS. All five mussels had northern *mt-az* mitochondria (Table 3) and allozyme genotypes consistent with that of the northern parental species, *B. azoricus* (Fig. 5). Perhaps they carried natal

symbionts that were gradually being replaced by local symbionts. Nevertheless, this leaky vertical transmission scenario remains speculative, because the present genotypic assignments had little power with current genetic markers.

The pathways used by vent animals to acquire or transmit symbiotic bacteria have fundamental implications regarding evolutionary histories, biogeography, and ecological constraints affecting hosts and symbionts. Vertical transmission, as seen in vesicomid clams, is efficient. Dispersing larvae carry the thiotrophic symbionts they need to colonize and grow at nascent vent fields and other sulfide-rich deep-sea habitats. Nevertheless, vesicomid clams are not common at vents in the Atlantic and Indian Oceans, and their distribution is spotty at Pacific vents. They are far more abundant at cold seeps, where sulfide regimes appear to be more stable (44). In contrast, the acquisition of locally adapted microbes might provide settling vestimentiferan tubeworms and *Bathymodiolus* mussels with the flexibility needed to exploit a wider range of geochemical regimes. Vestimentiferans are only abundant at Pacific vents and seeps and in Gulf of Mexico seeps. *Bathymodiolus* mussels, on the other hand, are nearly ubiquitous at hydrothermal vents, cold-water sulfide-hydrocarbon seeps, and other sites of organic enrichment (e.g., sunken wood and whale bones) in the Atlantic, Pacific, and Indian Oceans (15). Unlike clams and tubeworms, mussels can exploit thiotrophic and methanotrophic symbionts. Our ongoing study of variation among the methanotrophic endosymbionts of MAR mussels has revealed highly heterogeneous mixtures of bacterial strains, which is consistent with environmental acquisition of these endosymbionts as well (S. Hallam, unpublished data). Perhaps this remarkable capacity of *Bathymodiolus* mussels to acquire and exploit locally adapted species and strains of thiotrophic and methanotrophic microbes contributes to their wide distribution and ecological success at vents and seeps globally.

ACKNOWLEDGMENTS

We thank the crew and pilots of the R/V *Atlantis* and the DSV *Alvin* for their significant efforts and technical support. We also thank the scientists aboard R/V *Atlantis* during the MAR 1997 and 2001 cruises. We thank Robbie Young, Joe Jones, Peter Smouse, Grant Pogson, and Rich Lutz for helpful criticisms and guidance.

The present research was funded by grants from the National Science Foundation (grant numbers OCE9633131, OCE9910799, and OCE0241613) and by generous support from the Monterey Bay Aquarium Research Institute.

REFERENCES

1. Banks, M. A., and W. Eichert. 2000. WHICHRUN (version 3.2), a computer program for population assignment of individuals based on multilocus genotype data. *J. Hered.* **91**:87–89.
2. Birky, C. W. J., T. Maruyama, and P. Fuerst. 1983. An approach to population and evolutionary genetic theory for genes in mitochondria and chloroplasts, and some results. *Genetics* **103**:513–527.
3. Boss, K. J., and R. D. Turner. 1980. The giant white clam from the Galapagos rift, *Calyptogena magnifica* species novum. *Malacologia* **20**:161–194.
4. Cary, S. C. 1994. Vertical transmission of a chemoautotrophic symbiont in the protobranch bivalve, *Solemya reidi*. *Mol. Mar. Biol. Biotechnol.* **3**:121–130.
5. Cary, S. C., and S. J. Giovannoni. 1993. Transovarial inheritance of endosymbiotic bacteria in clams inhabiting deep-sea hydrothermal vents and cold seeps. *Proc. Natl. Acad. Sci. USA* **90**:5695–5699.
6. Cavanaugh, C. M. 1983. Chemoautotrophic bacteria in marine invertebrates from sulfide-rich habitats: a new symbiosis, p. 699–708. *In* H. E. A. Schenk and W. Schwemmler (ed.), *Endocytobiology II*. De Gruyter, Berlin, Germany.
7. Cavanaugh, C. M. 1994. Microbial symbiosis: patterns of diversity in the marine environment. *Am. Zool.* **34**:79–89.

8. Cavanaugh, C. M., P. R. Levering, J. S. Maki, R. Mitchell, and M. E. Lidstrom. 1987. Symbiosis of methylophilic bacteria and deep-sea mussels. *Nature* **325**:346–348.
9. Cavanaugh, C. M., C. O. Wirsen, and H. W. Jannasch. 1992. Evidence for methylophilic symbionts in a hydrothermal vent mussel (*Bivalvia*: Mytilidae) from the Mid-Atlantic Ridge. *Appl. Environ. Microbiol.* **58**:3799–3803.
10. Childress, J. J., H. Felbeck, and G. N. Somero. 1987. Symbiosis in the deep sea. *Sci. Am.* **255**:114–120.
11. Childress, J. J., and C. R. Fisher. 1992. The biology of hydrothermal vent animals: physiology, biochemistry and autotrophic symbioses. *Oceanogr. Mar. Biol. Annu. Rev.* **30**:337–441.
12. Corliss, J. B., and R. D. Ballard. 1977. Oasis of life in the cold abyss. *Nat. Geogr. Mag.* **152**:441–453.
13. Daffonchio, D., A. Cherif, and S. Borin. 2000. Homoduplex and heteroduplex polymorphisms of the amplified ribosomal 16S–23S internal transcribed spacers describe genetic relationships in the “*Bacillus cereus* group.” *Appl. Environ. Microbiol.* **66**:5460–5468.
14. DiMeo, C. A., A. E. Wilbur, W. E. Holben, R. A. Feldman, R. C. Vrijenhoek, and S. C. Cary. 2000. Genetic variation among endosymbionts of widely distributed vestimentiferan tubeworms. *Appl. Environ. Microbiol.* **66**:651–658.
15. Distel, D. L., A. R. Baco, E. Chuang, W. Morrill, C. M. Cavanaugh, and C. R. Smith. 2000. Marine ecology: do mussels take wooden steps to deep-sea vents? *Nature* **403**:725–726.
16. Distel, D. L., H. Felbeck, and C. M. Cavanaugh. 1994. Evidence for phylogenetic congruence among sulfur-oxidizing chemoautotrophic bacterial endosymbionts and their bivalve hosts. *J. Mol. Evol.* **38**:533–542.
17. Distel, D. L., D. J. Lane, G. J. Olsen, S. J. Giovannoni, B. Pace, N. R. Pace, D. A. Stahl, and H. Felbeck. 1988. Sulfur-oxidizing bacterial endosymbionts: analysis of phylogeny and specificity by 16S rRNA sequences. *J. Bacteriol.* **170**:2506–2510.
18. Distel, D. L., H. K. Lee, and C. M. Cavanaugh. 1995. Intracellular coexistence of methano- and thioautotrophic bacteria in a hydrothermal vent mussel. *Proc. Natl. Acad. Sci. USA* **92**:9598–9602.
19. Endow, K., and S. Ohta. 1990. Occurrence of bacteria in the primary oocytes of vesicomyid clam *Calyptogena soyoe*. *Mar. Ecol. Prog. Ser.* **64**:309–311.
20. Felbeck, H., J. J. Childress, and G. N. Somero. 1981. Calvin-Benson cycle and sulphide oxidation enzymes in animals from sulphide-rich habitats. *Nature* **293**:291–293.
21. Felbeck, H., and G. N. Somero. 1982. Primary production in deep-sea hydrothermal vent organisms: roles of sulfide-oxidizing bacteria. *Trends Biochem. Sci.* **7**:201–204.
22. Fiala-Medioni, A., A. M. Alayse, and G. Cahet. 1986. Evidence of in situ uptake and incorporation of bicarbonate and amino acids by a hydrothermal vent mussel. *J. Exp. Mar. Biol. Ecol.* **96**:191–198.
23. Fiala-Medioni, A., Z. P. McKiness, P. Dando, J. Boulegue, A. Mariotti, A. M. Alayse-Danet, J. J. Robinson, and C. M. Cavanaugh. 2002. Ultrastructural, biochemical, and immunological characterization of two populations of the mytilid mussel *Bathymodiolus azoricus* from the Mid-Atlantic Ridge: evidence for a dual symbiosis. *Mar. Biol.* **141**:1035–1044.
24. Fisher, C. R. 1990. Chemoautotrophic and methanotrophic symbioses in marine invertebrates. *Rev. Aquat. Sci.* **2**:399–436.
25. Fisher, C. R., J. J. Childress, A. J. Arp, J. M. Brooks, D. Distel, J. A. Favuzzi, H. Felbeck, R. Hessler, K. S. Johnson, M. C. Kennicutt II, S. A. Macko, A. Newton, M. A. Powell, G. N. Somero, and T. Soto. 1988. Microhabitat variation in the hydrothermal vent mussel, *Bathymodiolus thermophilus*, at the Rose Garden vent on the Galapagos Rift. *Deep-Sea Res.* **35**:1769–1791.
26. Fisher, C. R., J. J. Childress, R. S. Oremland, and R. R. Bidigare. 1987. The importance of methane and thiosulfate in the metabolism of the bacterial symbionts of two deep-sea mussels. *Mar. Biol.* **96**:59–71.
27. Fujiwara, Y., C. Kato, N. Masui, K. Fujikura, and S. Kojima. 2001. Dual symbiosis in the cold-seep thyasirid clam *Maorithyas hadalis* from the hadal zone in the Japan Trench, western Pacific. *Mar. Ecol. Prog. Ser.* **214**:151–159.
28. Fujiwara, Y., K. Takai, K. Uematsu, S. Tsuchida, J. C. Hunt, and J. Hashimoto. 2000. Phylogenetic characterization of endosymbionts in three hydrothermal vent mussels: influence on host distributions. *Mar. Ecol. Prog. Ser.* **208**:147–155.
29. Giberson, R. T., R. S. Demaree, Jr., and R. W. Nordhausen. 1997. Four-hour processing of clinical/diagnostic specimens for electron microscopy using microwave technique. *J. Vet. Diagn. Investig.* **9**:61–67.
30. Gustafson, R. G., and R. G. B. Reid. 1988. Association of bacteria with larvae of the gutless protobranch bivalve *Solemya reidi* (Cryptodonta: Solemyidae). *Mar. Biol.* **97**:389–401.
31. Herry, A., and M. Le Pennec. 1986. Ultrastructure de la gonade d'un *Mytilidae* hydrothermal profond de la ride du Pacifique oriental. *Haliotis* **16**:295–307.
32. Hurtado, L. A., M. Mateos, R. A. Lutz, and R. C. Vrijenhoek. 2003. Coupling of bacterial endosymbiont and host mitochondrial genomes in the hydrothermal vent clam *Calyptogena magnifica*. *Appl. Environ. Microbiol.* **69**:2058–2064.
33. Kenk, V. C., and B. R. Wilson. 1985. A new mussel (*Bivalvia*, Mytilidae) from hydrothermal vents in the Galapagos Rift zone. *Malacologia* **26**:253–271.
34. Kumar, S., K. Tamura, and M. Nei. 1994. MEGA: Molecular Evolutionary Genetics Analysis software for microcomputers, v. 1.01. *Comput. Appl. Biosci.* **10**:189–191.
35. Le Pennec, M., M. Diouris, and A. Herry. 1988. Endocytosis and lysis of bacteria in gill epithelium of *Bathymodiolus thermophilus*, *Thyasira flexuosa* and *Lucinella divaricata* (bivalve, molluscs). *J. Shellfish Res.* **7**:483–489.
36. Maas, P. A. Y., G. D. O'Mullan, R. A. Lutz, and R. C. Vrijenhoek. 1999. Genetic and morphometric characterization of mussels (*Bivalvia*: Mytilidae) from mid-atlantic hydrothermal vents. *Biol. Bull.* **196**:265–272.
37. McMullin, E., S. Hourdez, S. W. Schaeffer, and C. R. Fisher. 2003. Phylogeny and biogeography of deep-sea vestimentiferans and their bacterial symbionts. *Symbiosis* **34**:1–41.
38. Nelson, D. C., and C. R. Fisher. 1995. Chemoautotrophic and methanotrophic endosymbiotic bacteria at deep-sea vents and seeps, p. 125–167. *In* D. M. Karl (ed.), *Microbiology of deep-sea hydrothermal vent habitats*. CRC Press, Boca Raton, Fla.
39. O'Mullan, G. D., P. A. Y. Maas, R. A. Lutz, and R. C. Vrijenhoek. 2001. A hybrid zone between hydrothermal vent mussels (*Bivalvia*: Mytilidae) from the Mid-Atlantic Ridge. *Mol. Ecol.* **10**:2819–2831.
40. Peek, A. S., R. A. Feldman, R. A. Lutz, and R. C. Vrijenhoek. 1998. Cospeciation of chemoautotrophic bacteria and deep-sea clams. *Proc. Natl. Acad. Sci. USA* **95**:9962–9966.
41. Perrot-Minnot, M.-J., L. R. Guo, and J. H. Werren. 1996. Single and double infections with *Wolbachia* in the parasitic wasp *Nasonia virtipennis*: effects on compatibility. *Genetics* **143**:961–972.
42. Rau, G. H. 1981. Hydrothermal vent clam and tube worm $^{13}\text{C}/^{12}\text{C}$: further evidence of nonphotosynthetic food sources. *Science* **213**:338–340.
43. Robinson, J. J., M. F. Polz, A. Fiala-Medioni, and C. M. Cavanaugh. 1998. Physiological and immunological evidence for two distinct C_1 -utilizing pathways in *Bathymodiolus puteoserpentis* (*Bivalvia*: Mytilidae), a dual endosymbiotic mussel from the Mid-Atlantic Ridge. *Mar. Biol.* **132**:625–633.
44. Sibuet, M., and K. Olu. 1998. Biogeography, biodiversity and fluid dependence of deep-sea cold-seep communities at active and passive margins. *Deep-Sea Res. Part II* **45**:517–567.
45. Skibinski, D. O. F., C. Gallagher, and C. M. Benyon. 1994. Mitochondrial DNA inheritance. *Nature* **368**:817–818.
46. Thompson, J. D., D. G. Higgins, and T. J. Gibson. 1994. CLUSTAL W: improving the sensitivity of progressive multiple sequence alignment through sequence weighting, position-specific gap penalties and weight matrix choice. *Nucleic Acids Res.* **22**:4673–4680.
47. Trask, J. L., and C. L. Van Dover. 1999. Site-specific and ontogenetic variations in nutrition of mussels (*Bathymodiolus* sp.) from the Lucky Strike hydrothermal vent field, Mid-Atlantic Ridge. *Limnol. Oceanogr.* **44**:334–343.
48. Van Dover, C. L. 2000. *The ecology of deep-sea hydrothermal vents*. Princeton University Press, Princeton, N.J.
49. Werren, J. H. 1997. Biology of *Wolbachia*. *Annu. Rev. Entomol.* **42**:587–609.
50. Windoffer, R., and O. Giere. 1997. Symbiosis of the hydrothermal vent gastropod *Ifremeria nautiliei* (Provannidae) with endobacteria—structural analyses and ecological considerations. *Biol. Bull.* **193**:381–392.
51. Won, Y., S. J. Hallam, G. D. O'Mullan, and R. C. Vrijenhoek. 2003. Cytonuclear disequilibrium in a hybrid zone involving hydrothermal vent mussels (genus *Bathymodiolus*). *Mol. Ecol.*, in press.
52. Zouros, E., A. O. Ball, C. Saavedra, and K. R. Freeman. 1994. Mitochondrial DNA inheritance. *Nature* **368**:818.